



## Wireless Chime Relay Installation Guide

for use with Control4

### Existing Doorbell Wireless Retrofit 4

Since the wires to the doorbell typically run via the doorbell button, and are opened or closed by the traditional doorbell switch, the traditional doorbell button needs to be removed and the wires leading to the doorbell button need to be connected to each other permanently. This maintains the existing power connection to power the device. Also if a rear doorbell is installed the wires leading to the rear doorbell must be disconnected and capped.

### Overview 2

The Axxess Chime relay can be installed in, or next to, a powered chime that is powered by a typical doorbell transformer (typically 16V, but 12V to 18V AC are permitted). The best mounting option will depend on the specific device location, and may include double sided tape or wood or wire screws.

### Included

- Chime Relay Device
- 2 pcs ½ wide double sided foam tape for base mounting
- Wire Nuts

### General Wiring Instructions 3

If there is no existing wiring powering the chime, you will need to install a power supply/transformer and lead the secondary wires to the chime location.

**Before doing any re-wiring, locate the transformer powering the existing chime/doorbell unit and disconnect the secondary wires at the transformer, securing the leads to avoid shorts or arcing.**

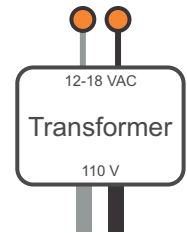

### Chime Relay Connections 5

The Axxess Chime relay has 4 flying leads, red, black, blue and yellow. Connect the following wires as follows:

- Red** to one of the leads from the transformer
- Blue** to chime contact typically marked "Front"
- Black** to chime contact typically marked "Trans/Common"
- Yellow** to chime contact typically marked "Rear"

The second transformer lead will connect to the same contact as the black wire, typically marked "Trans/Common".



### Existing Wiring 7

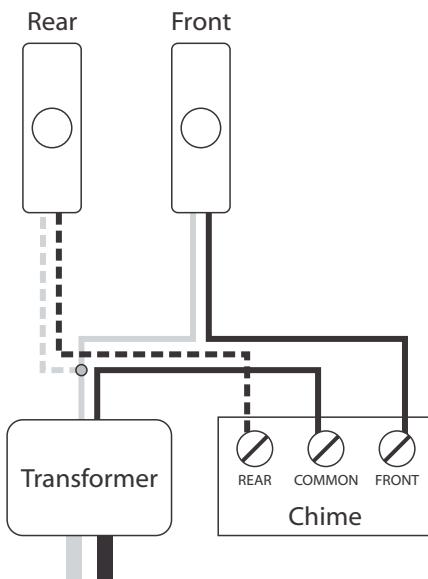

### Wireless Doorbell Buttons 8

Wired doorbell buttons must be replaced with wireless ZigBee doorbell buttons. These can be ordered from Axxess separately from the chime relay.

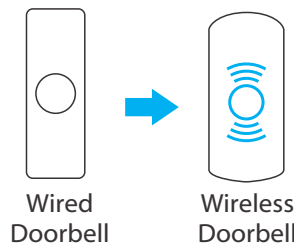

**Modify**

### Modified Wiring 9

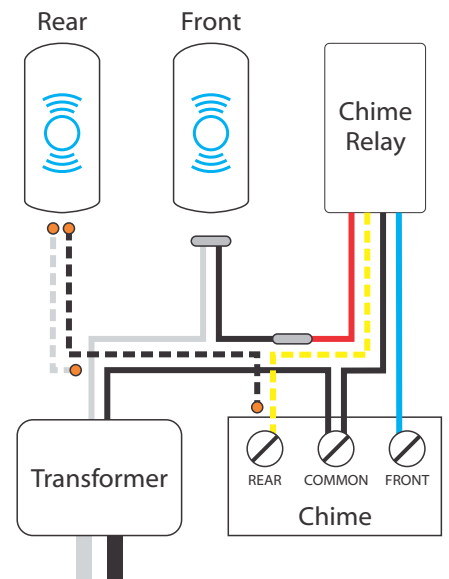

### New Wireless Installation

10

The same general instructions apply to a new installation. As opposed to an existing installation the transformer wiring can now be connected directly to the chime and chime relay. Wireless Doorbell Buttons and Chime Relays can be mounted anywhere within range of the ZigBee network.

### New Wiring

11

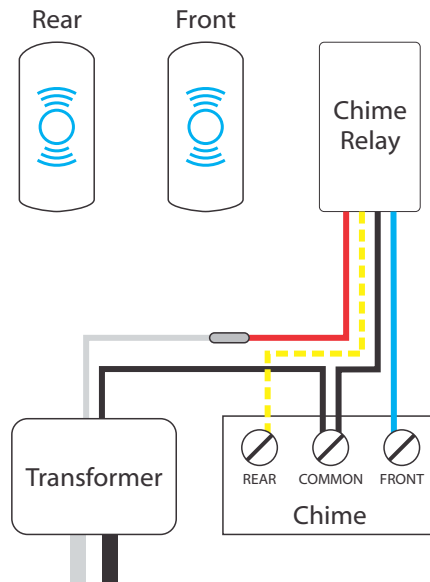

### Finishing Installation

12

Ensure that neither the wires, nor the chime relay touch the chime sound bars, as even a slight touch will dull the sound. After re-wiring ensure there are no exposed uncapped wires, then reconnect the secondary wires at the transformer.

### ZigBee Network

13

The device has to be mounted within the range of the ZigBee network in which it is to operate.

A network push button is located inside the smaller of the 2 openings in the side of the chime relay case. Use a paper clip to press the button.

- Join: 4 taps \* 6 flashes - long solid flash when joined
- Leave: 13 taps \* 6 flashes
- Test: 8 taps \* Triggers chime
- Reset: 15 taps \* 6 flashes if not joined or long solid flash if joined

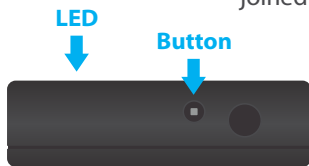

### ZigBee Network (Cont'd)

14

The range can vary depending on the strength of the router it is connected to, as well as physical obstructions. Typically the device can communicate up to 400 feet in the open, however, this can be reduced to 40 feet when indoors depending on the routing device. Ensure the network is designed properly and that router strength and physical barriers are considered.

### Composer

15

Instructions for how to use with composer can be accessed on our website at: [axxind.com/dealers/composer](http://axxind.com/dealers/composer)

### Drivers

Control4 device Drivers are available for download on our website: [axxind.com/dealers/drivers](http://axxind.com/dealers/drivers)

The parameters that may be set up in the device driver are self-explanatory. The properties page contains a battery level value, which may be programmed against to provide notification for battery replacement.

### Testing

16

It is important to make sure that the device is wired properly. To test that the device has power and is properly connected test the chime by 8 tapping the network button. This should trigger the Front Chime.

Create the necessary binding and execute the programming. You should hear the chime.

### Troubleshooting

17

It is important to make sure that the device is wired properly. To test that the device has power and is properly connected test the chime by 8 tapping the network button. This should trigger the Front Chime.

If the chime triggers locally, but you cannot trigger the chime from Composer then there is a network issue. Make sure the relay is in range of the Zigbee network and confirm that it is joined. If necessary, leave the device and rejoin it to the network.

If the chime does not trigger locally then there is a problem with the wiring or with the device.

Double check that the device is wired correctly and try to test again by 8 tapping the network button.

To test that the device is powered up, confirm that there is LED feedback when you tap the network button to join or leave the device. If there is no LED feedback then the device has no power. Check wiring and connections. If they are correct then there may be a problem with the device.

If there is power to the device but the chime does still not trigger locally, confirm that the wiring on the chime is correct and that there is not a problem with the chime. If it still does not trigger than there may be a problem with the device.

Troubleshooting instructions can be accessed on our website at: [axxind.com/dealers/troubleshooting](http://axxind.com/dealers/troubleshooting)